

## Indoor/Outdoor Modular Intercom System

Refer to your Owner's Manual for complete instructions.

### PREPARATION

1. Remove the doorbell's battery compartment cover.
2. Insert 4 AA batteries.

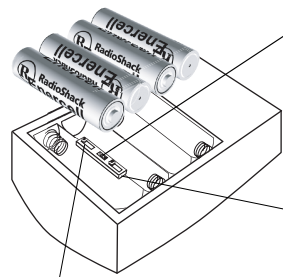

3. To change the doorbell tone, use a flat blade screwdriver to remove **TONE**, and insert it into the other two pins.
4. Slide **CH 1 2 3** to the same channel as the indoor intercom.

5. Slide **VOL 1 2 3** to the desired volume and replace the cover.

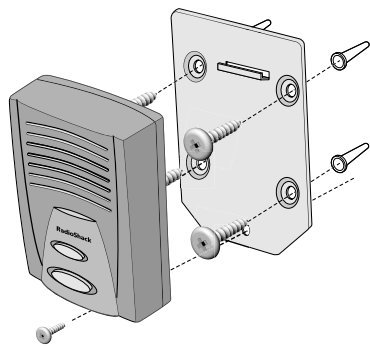

6. Plug the indoor intercom into a standard AC outlet.
7. Mount the doorbell using the supplied bracket, anchors, and screws as shown.

Doorbell Intercom

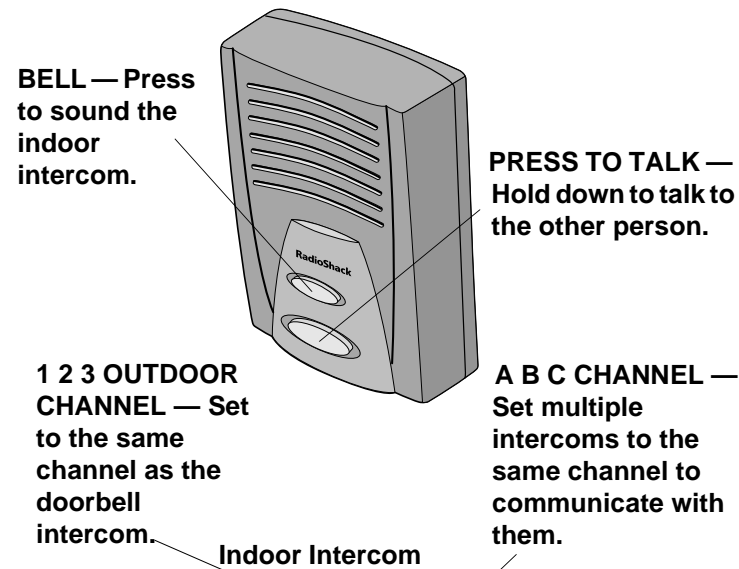

Indoor Intercom

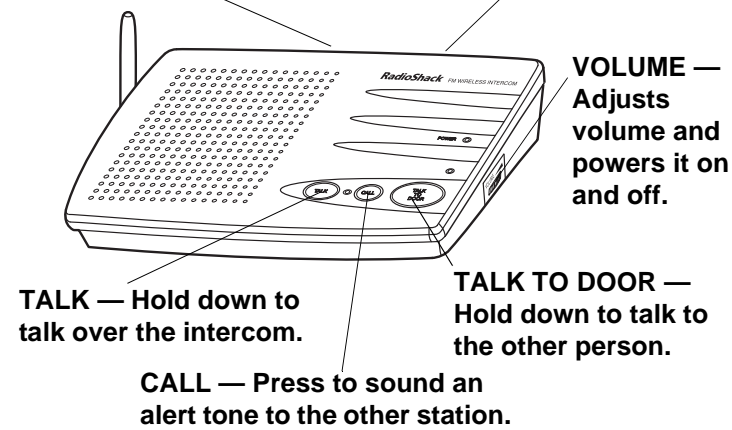

8. If desired, mount the indoor intercom using the supplied anchors and screws as shown.

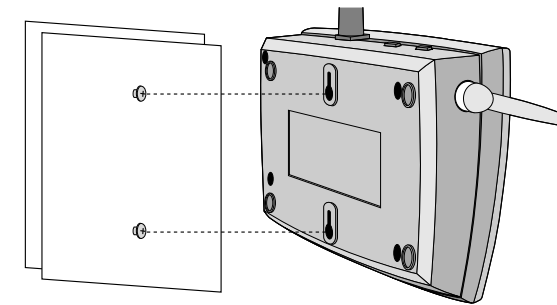

### OPERATION

1. Rotate **VOLUME** on the indoor intercom counterclockwise until it clicks. Then adjust **VOLUME** to the desired listening level.
2. To turn off the indoor intercom, rotate **VOLUME** clockwise until it clicks.
3. Press **BELL** on the doorbell to sound the indoor intercom. Hold down **TALK TO DOOR** on the indoor intercom to reply. When you release **TALK TO DOOR**, the caller can reply by holding down **PRESS TO TALK** on the doorbell intercom.

## USING MULTIPLE INTERCOMS

You can set up several indoor intercoms for station-to-station communication. Simply set **CHANNEL A B C** on the back of each intercom to the same frequency as other stations with which you want to communicate. For example, if you set all stations to channel **A**, you can communicate with the other two stations from any station. You could also set a station installed in the kitchen to channel **A**, a station installed in the family room to channel **B**, and a station installed in a bedroom to channel **C**. Using the station installed in the kitchen, you can communicate with the station in the family room by setting the channel selector to **B**, or with the station in the bedroom by setting the channel selector to **C**.

## CALLING ANOTHER STATION

Be sure the intercom stations you plan to use are turned on and adjusted to the desired volume. Press **CALL** to sound a tone alerting the person at the other station that you are about to speak. The **CALL** indicator lights.

## CAUTIONS AND WARNINGS

- Dispose of old batteries promptly and properly. Do not burn or bury them.
- Use only fresh batteries of the required size and recommended type. Do not mix old and new batteries, different types of batteries, or rechargeable batteries of different capacities.
- If you do not plan to use the doorbell for two weeks or longer, remove the batteries. Batteries can leak chemicals that can destroy electronic parts.
- This product is equipped with a three-wire grounding-type plug. This plug only fits into a grounding-type power outlet. If you are unable to insert the plug into your AC outlet, contact your electrician to replace your outlet.
- Be sure you install the stations at least 10 feet away from each other. Placing the stations too close together produces feedback (a squeal or howl from the speakers). The stations can transmit up to 300 feet, including between buildings, as long as they are connected to the same power line transformer.

RadioShack Corporation  
Fort Worth, Texas 76102

## NOTES

- There are two levels of low battery condition. The door bell unit still works correctly at level 1. It does not work at level 2. When it reaches the first level, the indoor unit sounds an alert tone for about five seconds and **POWER** blinks periodically. If there is no key press before the replacement of new batteries, the indoor unit sounds a beep tone every minute. It can be stopped by pressing any key on the indoor unit. If **BELL** is pressed at level 1, or the indoor unit is reset at level 1 or 2, **POWER** returns to normal in about two minutes, and another low battery signal is sent to the indoor intercom. The indoor intercom sounds an alert tone again for about five seconds, then sounds a reminder beep every minute.
- The doorbell and indoor intercoms have three selectable operation channels to prevent interference from similar products nearby. Select the same channel for both the doorbell intercom and the indoor intercom.
- If the doorbell occasionally sounds without anyone pressing **BELL**, change the channel settings.
- If there is no voice communication between the doorbell and the indoor intercom within about 10 seconds, the intercom may be disabled and should be initialized by pressing **BELL** again.

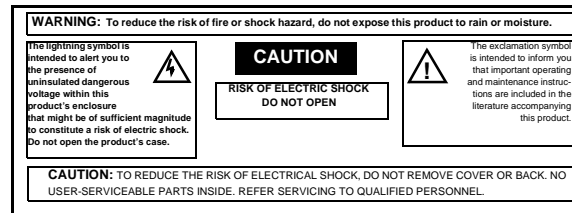

## CARE

Keep the system dry; if it gets wet, wipe it dry immediately. Use and store the system only in normal temperature environments. Handle the system carefully; do not drop it. Keep the system away from dust and dirt, and wipe it with a damp cloth occasionally to keep it looking new.

Modifying or tampering with the system's internal components can cause a malfunction and might invalidate its warranty and void your FCC authorization to operate it. If your system is not performing as it should, take it to your local RadioShack store for assistance.

## FCC INFORMATION

This device complies with part 15 of the *FCC Rules*. Operation is subject to the following two conditions: (1) this device may not cause harmful interference, and (2) this device must accept any interference received, including interference that may cause undesired operation.

Changes or modifications to this unit not expressly approved by the party responsible for compliance could void the user's authority to operate the equipment.

This equipment has been tested and found to comply with the limits for a Class B digital device, pursuant to Part 15 of the *FCC Rules*. These limits are designed to provide reasonable protection against harmful interference in a residential installation. This equipment generates, uses, and can radiate radio frequency energy and, if not installed and used in accordance with the instructions, may cause harmful interference to radio communications. However, there is no guarantee that interference will not occur in a particular installation. If this equipment does cause harmful interference to radio or television reception, which can be determined by turning the equipment off and on, the user is encouraged to try to correct the interference by one or more of the following measures:

- Reorient or relocate the receiving antenna
- Increase the separation between the equipment and receiver.
- Connect the equipment into an outlet on a circuit different from that to which the receiver is connected.
- Consult the dealer or an experienced radio TV technician for help.

Your system is ETL listed to UL standards and meets all applicable FCC requirements.

### Limited Ninety-Day Warranty

This product is warranted by RadioShack against manufacturing defects in material and workmanship under normal use for ninety (90) days from the date of purchase from RadioShack company-owned stores and authorized RadioShack franchisees and dealers. EXCEPT AS PROVIDED HEREIN, RadioShack MAKES NO EXPRESS WARRANTIES AND ANY IMPLIED WARRANTIES, INCLUDING THOSE OF MERCHANTABILITY AND FITNESS FOR A PARTICULAR PURPOSE, ARE LIMITED IN DURATION TO THE DURATION OF THE WRITTEN LIMITED WARRANTIES CONTAINED HEREIN. EXCEPT AS PROVIDED HEREIN, RadioShack SHALL HAVE NO LIABILITY OR RESPONSIBILITY TO CUSTOMER OR ANY OTHER PERSON OR ENTITY WITH RESPECT TO ANY LIABILITY, LOSS OR DAMAGE CAUSED DIRECTLY OR INDIRECTLY BY USE OR PERFORMANCE OF THE PRODUCT OR ARISING OUT OF ANY BREACH OF THIS WARRANTY, INCLUDING, BUT NOT LIMITED TO, ANY DAMAGES RESULTING FROM INCONVENIENCE, LOSS OF TIME, DATA, PROPERTY, REVENUE, OR PROFIT OR ANY INDIRECT, SPECIAL, INCIDENTAL, OR CONSEQUENTIAL DAMAGES, EVEN IF RadioShack HAS BEEN ADVISED OF THE POSSIBILITY OF SUCH DAMAGES.

Some states do not allow limitations on how long an implied warranty lasts or the exclusion or limitation of incidental or consequential damages, so the above limitations or exclusions may not apply to you.

In the event of a product defect during the warranty period, take the product and the RadioShack sales receipt as proof of purchase date to any RadioShack store. RadioShack will, at its option, unless otherwise provided by law: (a) correct the defect by product repair without charge for parts and labor; (b) replace the product with one of the same or similar design; or (c) refund the purchase price. All replaced parts and products, and products on which a refund is made, become the property of RadioShack. New or reconditioned parts and products may be used in the performance of warranty service. Repaired or replaced parts and products are warranted for the remainder of the original warranty period. You will be charged for repair or replacement of the product made after the expiration of the warranty period.

This warranty does not cover: (a) damage or failure caused by or attributable to acts of God, abuse, accident, misuse, improper or abnormal usage, failure to follow instructions, improper installation or maintenance, alteration, lightning or other incidence of excess voltage or current; (b) any repairs other than those provided by a RadioShack Authorized Service Facility; (c) consumables such as fuses or batteries; (d) cosmetic damage; (e) transportation, shipping or insurance costs; or (f) costs of product removal, installation, set-up service adjustment or reinstallation.

This warranty gives you specific legal rights, and you may also have other rights which vary from state to state.

RadioShack Customer Relations, 200 Taylor Street, 6th Floor, Fort Worth, TX 76102

12/99

11A02  
AO0133ABA1  
Printed in China